

Flow Through Sampler PNL



Picture Courtesy of the Petroleum Engineering Department
at the Colorado School of Mines, Golden, CO USA



Sampling

The PNL is a flow through type sampler used to secure fluid and gas samples under reservoir conditions of temperature and pressure.

Application

The PNL is a flow-through type sampler used to secure fluid and gas samples under reservoir conditions of temperature and pressure and bring them to surface for PVT laboratory test. This is achieved with the Leutert sampler PNL by using a stainless steel tube through which oil and gas may flow whilst lowering the instrument into the well to the desired sampling depth.

The PNL is then closed mechanically by either a jar head, clock tripping mechanism or an electric motor trigger. The sampler is then pulled back to surface and the trapped sample may be evaluated in PVT laboratory analysis.

For safe transportation of the sample obtained by the PNL, it is usually required to transfer the sample into specially designed shipping bottles. For this procedure, Leutert also supplies the bottles, a high pressure mercury pump and all other necessary tools and instruments.

Sample Chamber

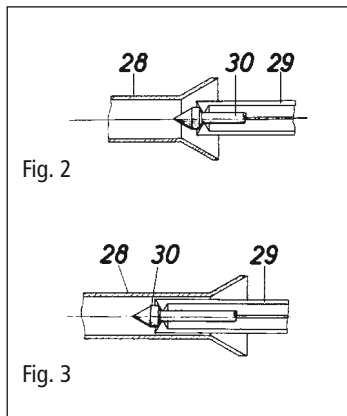

This chamber consists of two valve nipples (22), valves (32), outer casing (27) and the valve closing gear (24-31).

Operation as follows:

The lower valve (32) is joined to the shaft (30), the spearhead of which is gripped by the collet chuck (29) when the valve is open (Fig. 2). The upper valve (32 a) is joined to the shaft (24), the guides (25) and the sleeve (28).

When the upper valve is opened, the sleeve slides over and locks the collet chuck (29) (Fig. 3) and holds the lower valve open Fig. 3 as long as it is itself open.

The springs (19) are only powerful enough to assure a positive valve closure, if the pressure inside and outside the sample chamber is the same.

When pulling out of the well, pressure on the outside of the sampler decreases, so that the higher pressure inside the sampler chamber then acts on the valves cross section keeping them tightly closed.

The combination of springs and internal pressure is such that loss of fluid or gas from the sampler is only possible, if for some reason the external pressure exceeds the internal. In those rare cases, however, a positive lock assembly is available and should be employed.

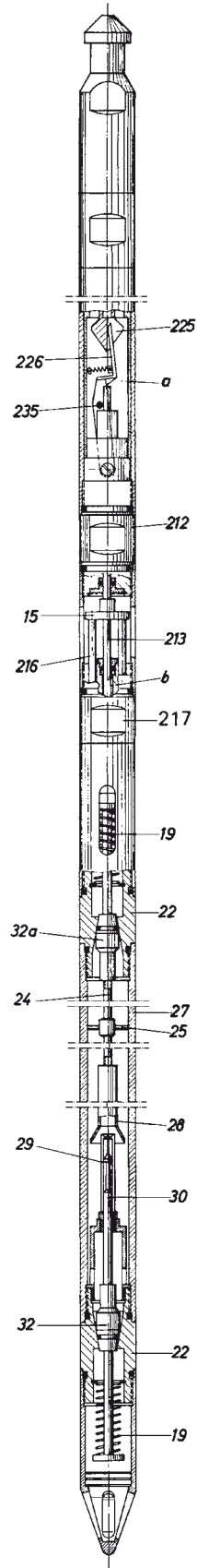

Fig. 1

Valve closing gear

This gear consists of the crosshead and shafts (15 and 216) passing through the nipple (217) the push rod (213) passing through the nipple (212) and the triggering lever (226), which allows the valves to close when it comes to rest in the slot of the cam (225) rotated by the clock.

The function of the push rod is an important one, because it ensures reliable working of the triggering mechanism and valve closing gear. It is a double acting plunger, with one end in the pressure-free space (a) and the other in the pressure-free space (b). It can, therefore, always move easily, even if the whole instrument is subjected to pressure. The only load on the trigger (226) and thus on the clockwork is that of the upper valve spring (19).

The trigger and clock unit is independent of the sample chamber and can be used for different sample chambers.

Technical Data PNL

Volume (standard)	Diameter	Total length	Total weight
600 ccm	40 mm 1 ³⁷ / ₆₄ "	2.2 m 86.6"	15 kg 33 lbs
1000 ccm	40 mm 1 ³⁷ / ₆₄ "	3.2 m 126"	18 kg 40 lbs

Total length is reduced by 0.45 m | 17.5" when using the LEUTERT Jarhead in place of the clock.

Pressure rating: standard 700 bar | 10,000 psi
up to 1400 bar | 20,000 psi

Valve opener

to release the sample from the chamber

Special valve openers are required for this job. After the lower spear point (bull nose) and the triggering mechanism have been unscrewed, the valve openers are fitted in their place.

By noting the dial gauge attached, the increase in pressure can be seen when the sampler valve is opened. It is recommended to always have two valve openers available when planning the transfer of a sample at a field location.

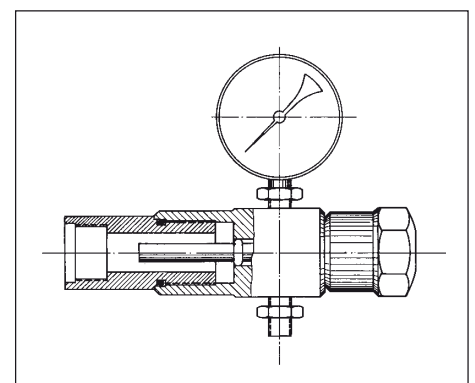

Accessories for PNL

- The entire sample transfer system including sample bottles and mercury pump
- Sample bottles for H₂S service available

